

| | | | |
|----------------------|--|------------------------|--|
| G.V.W.R | 23,400# | ELECTRIC PLUG | 7-Way RV Style |
| COUPLER | 2 5/16" E-Z Adjustable Coupler | PREP | 3-Step Acid Washed with Phosphorus Solution |
| AXLES | Tandem 10,000# Dual Wheel (Oil-Bath) | PRIMER | Dupont Primer |
| SUSPENSION | Multi-leaf Slipper Spring with Equalizer | PAINT | Dupont Automotive-grade Acrylic Enamel |
| TIRE | ST235/80R16 (10 ply) | PINSTRIPES | Painted Pinstripes |
| WHEEL | 16 x 6 Dual 8-bolt | OVERALL WIDTH | 102" wide (approx) |
| FRAME | 12", (19 lbs./ft.) | DECK HEIGHT | Approx. 38" standard |
| NECK | 12" I-Beam (19# lbs./ft.) | BRAKES | Electric brakes on all axles |
| CROSSMEMBERS | 3" Channel on 16" centers | DOVE TAIL | Your choice of 3 different Dove Tail styles |
| SAFETY CHAINS | 3/8" Heavy Duty with Safety Latch Hooks | STEPS | Access Step on driver's side |
| JACK | 12,000# Spring Loaded Drop Leg Jack | STORAGE | Storage Area in A-Frame (Expanded Metal) |
| SIDE RAILS | 5" Angle Iron with Rub Rails & Stake Pockets | WIRING | Front Mount in conduit |
| STAKE POCKETS | Formed Stake Pockets on 24" centers | REFLECTIVE TAPE | Required D.O.T. Reflective Taping |
| FLOOR | 2" Pressure Treated Pine | SAFETY | Emergency Breakaway switch & battery backup |
| LIGHTS | All LED Stop, Tail, Turn and Clearance | | All specifications subject to change without notice. |

Measurements

26' model shown (6' + 20')

| Length | Tilt Deck | Front Deck | A | B | C |
|--------|-----------|------------|-----|------|-----|
| 26 | 20' | 6' | 312 | 177" | 38" |
| 30 | 20' | 10' | 360 | 237" | 38" |

All measurements are approximate

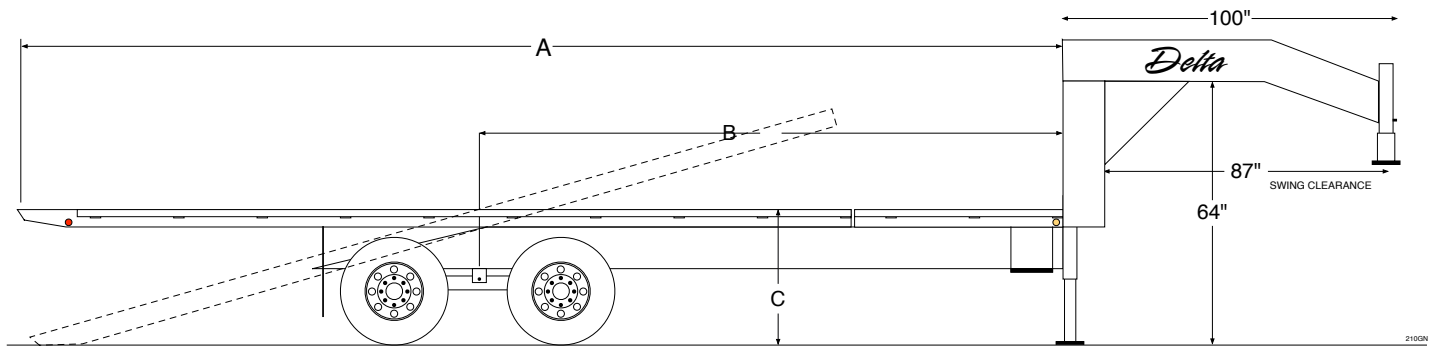

SUGGESTED RETAIL PRICE

| Model | Length | MSRP |
|----------|--|----------|
| 210GT-26 | 26' (6 ft. Fixed Deck + 20 ft. Tilt Deck) | \$12,119 |
| 210GT-30 | 30' (10 ft. Fixed Deck + 20 ft. Tilt Deck) | \$12,844 |

210GT OPTIONS PRICING

| | |
|---|---------|
| Disc Brakes (only available on 10K) | \$460 |
| Electric over Hydraulic Brakes | \$1,760 |
| Front Mount Toolbox with lid (only available with dual jack option) | \$229 |
| Side Mount Toolbox with lid | \$229 |
| Extra Spring Loaded Jack (Dual Jacks) | \$207 |
| 2-Speed Jack System (includes 2nd Jack) | \$375 |
| Pipe Spools (between Stake Pockets) | \$115 |
| Shrinkwrap Electrical Connections | \$76 |

| | |
|---|-------------|
| Torque Tube (helps minimize trailer twisting) | \$30/ft. |
| Metal Floor (3/16" Diamondplate with crossmembers on 12" centers) | \$69/ft. |
| Spare Wheel | \$92 |
| Spare (Complete Tire & Wheel) | \$245 |
| Paint Underside of Trailer (standard feature) | INCL |
| Upgrade 10K Heavy Duty axles | \$1,148 |
| Upgrade to 12", 22 lbs. I-Beam | \$15/ft. |
| Upgrade to 14-ply radial tires | \$69/tire |